

Operation Instruction

2-channel induction loop detector for installation on DIN-rail

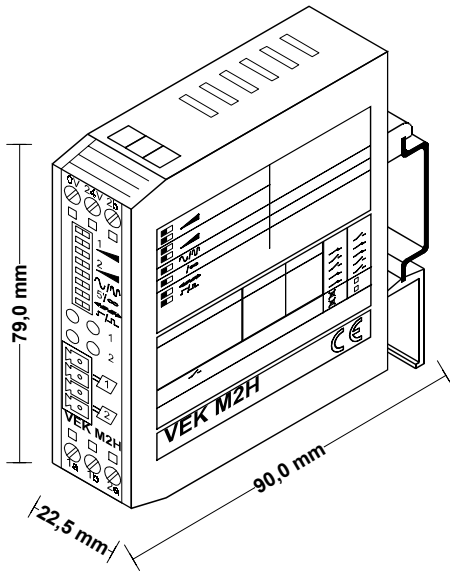

1 General

Applications:

- barrier controls
- door and gate controls
- parking and traffic technology

Features:

The induction loop detector VEK M2H is a system for inductive recognition of vehicles with the following characteristics:

- evaluation of two loops
- detection of vehicle presence or vehicle direction
- isolated transformer between loop and detector electronics
- automatic calibration of the system after power on
- continuous rebalancing of frequency drifts
- usable for single place parking space supervising
- no mutual influence of loop 1 and loop 2 by multiplexing
- sensitivity independent of the loop inductance
- presence signal by LED display
- potential free relay contacts for presence and pulse output
- principle of relay operation changeable
- signaling of loop frequency by LED
- loop connection plug-in for diagnosis

For planning and installation of loops please note our manual "detection of vehicles with the induction loop detector".

2 Setting options

2.1 Sensitivity

The setting of the sensitivity calls the electronics to a value of frequency deviation which a vehicle must produce for setting the output of the detector. The sensitivity can be adjusted for each channel in 4 steps with *DIP-switches* on top of the front panel.

sensitivity level		channel 1: DIP-Switch 1 and 2	channel 2: DIP-Switch 3 and 4
1 low	(0,64% $\Delta f/f$)		
2	(0,16% $\Delta f/f$)		
3	(0,04% $\Delta f/f$)		
4 high	(0,01% $\Delta f/f$)		

2.2 Frequency adjustment

The operation frequency of the detector can be adjusted in two steps with *DIP-switch 5*.

frequency	DIP-Switch 5
low	
high	

The permissible frequency range is 30kHz to 130kHz. The frequency depends on the loop inductivity (depending itself on: loop geometry, number of loop turns and loop lead) and the adjusted frequency step.

2.3 Hold time and Reset

The hold time can be adjusted with *DIP-switch 6*. At the completion of hold time it will be displayed "free loop" and the detector calibrates automatically. The hold time starts with the occupation of the loop.

hold time	DIP-switch 6
5 minutes	
infinite	

A reset with calibration can be effected by changing the hold time setting.

An automatic calibration of the loop frequency starts after power on. In case of short power cuts <0,1s there is no calibration.

2.4 Output mode

2.4.1 Presence output mode

For presence output mode *DIP-switch 7* is to be set to the left position. In this mode relay 1 signals presence on loop 1. The function of relay 2 can be set by *DIP-switch 8*.

output mode	DIP-switch 7 DIP-switch 8
both channels: presence output	
chan. 1: presence output chan. 2: pulse when loop gets free	

2.4.2 Direction output mode

For direction output mode *DIP-switch 7* is to be set to the right position. Two direction logics are supported depending on *DIP-switch 8*.

output mode	DIP-switch 7 DIP-switch 8
direction presence signal	
direction pulse signal	

The direction pulse signal is normally used for counting systems and the direction pulse signal for gate and barrier controls.

At the examples in the next column the operation principle of the direction logic is explained. The direction signal is output via the relay of the first covered loop i.e. signaling occurs in the case of driving direction 1->2 via relay 1 and in the case of driving direction 2->1 via relay 2.

In case of failure of one loop during direction output mode the detector operate in presence output mode independent of the setting of *DIP-switch 8*.

a) single vehicle

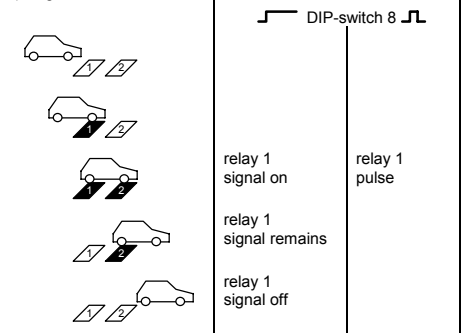

b) column traffic

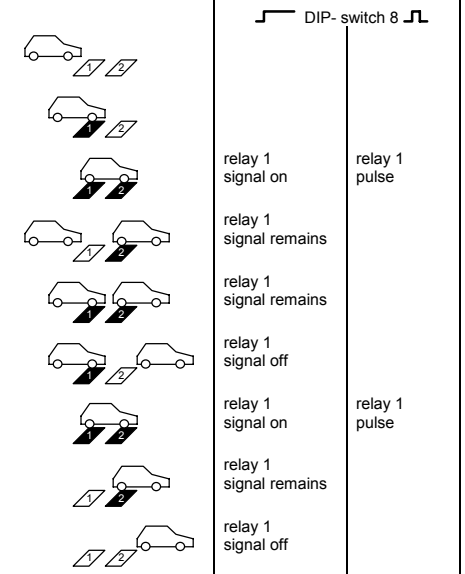

c) reversing vehicle

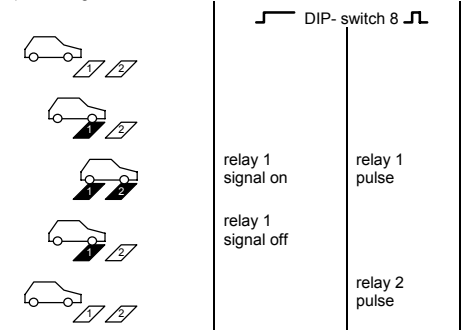

Please read these instructions and safety information and warnings attentively before initial operation of the detector !

3 Outputs and LED

3.1 Operating principle of the relays

In standard configuration both relays operate in the closed-circuit current mode where the break contacts are led onto the connections.

The operating principle of the relays can be changed according to the following table. For this modification, the detector housing must be opened carefully.

Attention! Static sensitive components are on the board. During works on the open device precautions are to be taken. Do not touch components or connections on the board. There is no guarantee in case of defects by inappropriate processing!

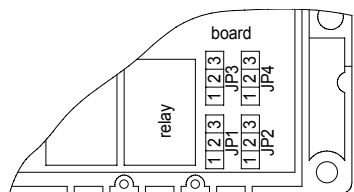

detector state	relay operating principle			
	I*)	II	III	IV
power off	—	—	—	—
loop free	—	—	—	—
output signal	—	—	—	—
loop failure	—	—	—	—

*) standard configuration

relay	jumper	position	relay function			
1	JP1	1-2	⊗	⊗	⊗	break contact
		2-3	⊗	⊗	⊗	make contact
	JP3	1-2	⊗	⊗	⊗	open-circuit principle
		2-3	⊗	⊗	⊗	close-circuit principle
2	JP2	1-2	○	○	○	break contact
		2-3	○	○	○	make contact
	JP4	1-2	⊗	⊗	⊗	open-circuit principle
		2-3	⊗	⊗	⊗	close-circuit principle

○ changeable by jumper

⊗ fixed by solder link

⊗ optionally setting (change solder link)

3.2 LED display

The green LED signals that the detector is ready for operation. Via the red LED, the activation of the relays output is displayed depending on the occupation status of the loop.

LED green loop control	LED red loop condition	detector function
off	off	power off
flashing	off	calibration or output of frequency
on	off	detector ready for operation, free loop
on	on	det. ready for operation, covered loop
off	on	loop failure

3.3 Output of loop frequency

Approx. 1 sec. after calibration of the detector the loop frequency will be displayed by pulse signals of the green LED. Firstly the 10kHz frequency value of the frequency value will be indicated. For every 10kHz frequency value the green LED flashes once. After a break of 1sec the 1kHz position is displayed in the same manner. If there is value of '0' in the 1kHz position there will be displayed 10 flashes. The flashes for 1kHz position are a little bit shorter than for the 10kHz position.

Example for 57kHz loop frequency:

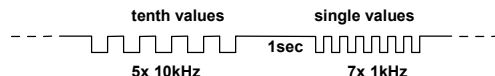

4 Connections

description	connection
power	0V 24V
relay 1	1a 1b
relay 2	2a 2b
loop 1 and loop 2	4-pole connection jack

5 Technical data

Dimensions	79x22.5x90 mm (h x w x d without plug)
Protection class	IP 40
Power supply	24V AC/DC ±10% max.2,0W
Operating temperature	-20 °C to +70 °C
Storing temperature	-20 °C to +70 °C
Humidity	max. 95 % not condensing
Loop inductivity	25-800 µH, recommended 100-300µH
Frequency range	30-130 kHz in 2 steps
Sensitivity	0,01 % up to 0,65 % (Δf/f) in 4 steps 0,02 % up to 1,3 % (ΔL/L)
Hold time	5 minutes or infinite
Loop lead length	max. 250 m
Loop resistance	max. 20 Ohm (incl. loop lead)
Relays reaction time	250mA / 24V AC/DC (min. 1mA/5V)
pick-up delay	typical 100 ms
signal duration	> 200 ms
releasing delay	typical 50 ms
Connections	screw terminals (power supply, relays) binder plug (loop connection)
CE- standards	EN 50082-2, Feb. 1996 EN 50081-1, March 1993

6 Safety information and warnings

- The device should only be used for the applications described by the manufacturer.
- Please keep this operation instruction always accessible and hand it over to every user.
- Inadmissible modifications to the device, use of repair parts and supplementary equipment which are not sold or recommended by the manufacturer can cause burning, electric shock and injuries. Therefore the manufacturer has no liability and this excludes all demands of warranty.
- The warranty regulations of the manufacturer are valid in the version of the purchase date for that device. There is no liability for not suitable, wrong manual or automatic adjustments also regarding no suitable applications of the device.
- Repairs may only be made by the manufacturer.
- All connections, the start-up, maintenance, measurements and adjustment operations to the detector have to be made from electrical specialists who have special know-how in the prevention of accidents.
- For the use of devices which have contact to electrical power, please pay attention to the valid security instructions and all prevention orders of fire and accidents.
- All operations with the device and its placement have to be done in accordance with national and general electrical instruction orders.
- The user is responsible for an installation, which has conformity to all technical rules in the country where the device is mounted, and also to all regional valid orders. For that the dimension of cabling, fuse protection, connection to ground, switch off, disconnection, isolation controlling and the protection for overload current have to be regarded in detail.
- The detector can not be used as a security device regarding to the security instructions of electrical machines. Using in systems with high danger potential it is necessary to include additional protection devices !

Hinweis

The information in this instruction can be changed without previous announcement.

With this description all previous issues lose their validity. The summary of information in this description was done with all possible acknowledge and by the best conscience.

LiftMaster can't give guaranty for the correctness of all information. Particularly there is no liability by *LiftMaster* for damages which result from a wrong installation of the device. In spite of all efforts to correctness we are very thankful for every point to a mistake in this description.

The installation recommendations in this description are based on optimum conditions. For wrong environment conditions *LiftMaster* doesn't give a warranty to optimum operation of the detector.